

**RA 501 E**  
**Motor**

As at: 09/20/11 Time:15:45

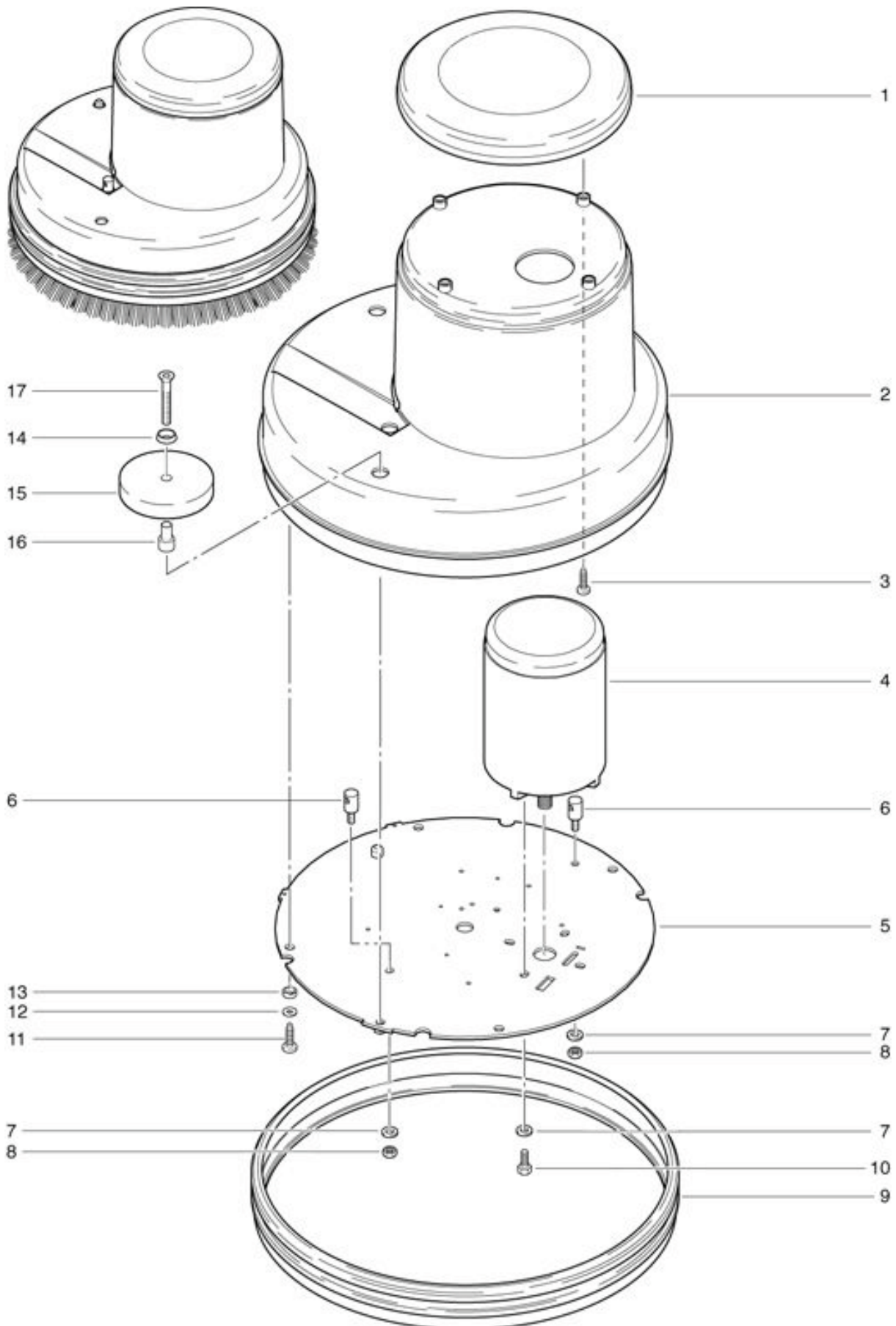

# RA 501 E

## Motor

As at: 09/20/11 Time:15:45

<b>Pos.</b>	<b>Description</b>	<b>Reference</b>
01	Cover	748.067 O
02	Cover	501.510
03	PT-screw KA 50x25	P...515 L
04	Motor 230V/50Hz	720.121
05	Drive disk	501.502
06	Hold bolt	432.505
07	Washer M 8x16	P...496 P
08	Hexagon nut M 8	P...492 H
09	Shock protection	501.515
10	Hexagon screw M 8x16	P...471 D
11	PT-screw KA 50x10	P...515 LA
12	Washer M 5	P...496 G
13	Distance ring	432.515
14	Disk for countersunk screw	P...500 T
15	Fender wheel Ø 90 mm	510.127
16	Distance ring	432.508
17	Countersunk screw M 8x45	P...479 P