

## Stromlaufplan R 43 / R 53-1100 230-240V / 50 Hz ab Masch. Nr. 8240

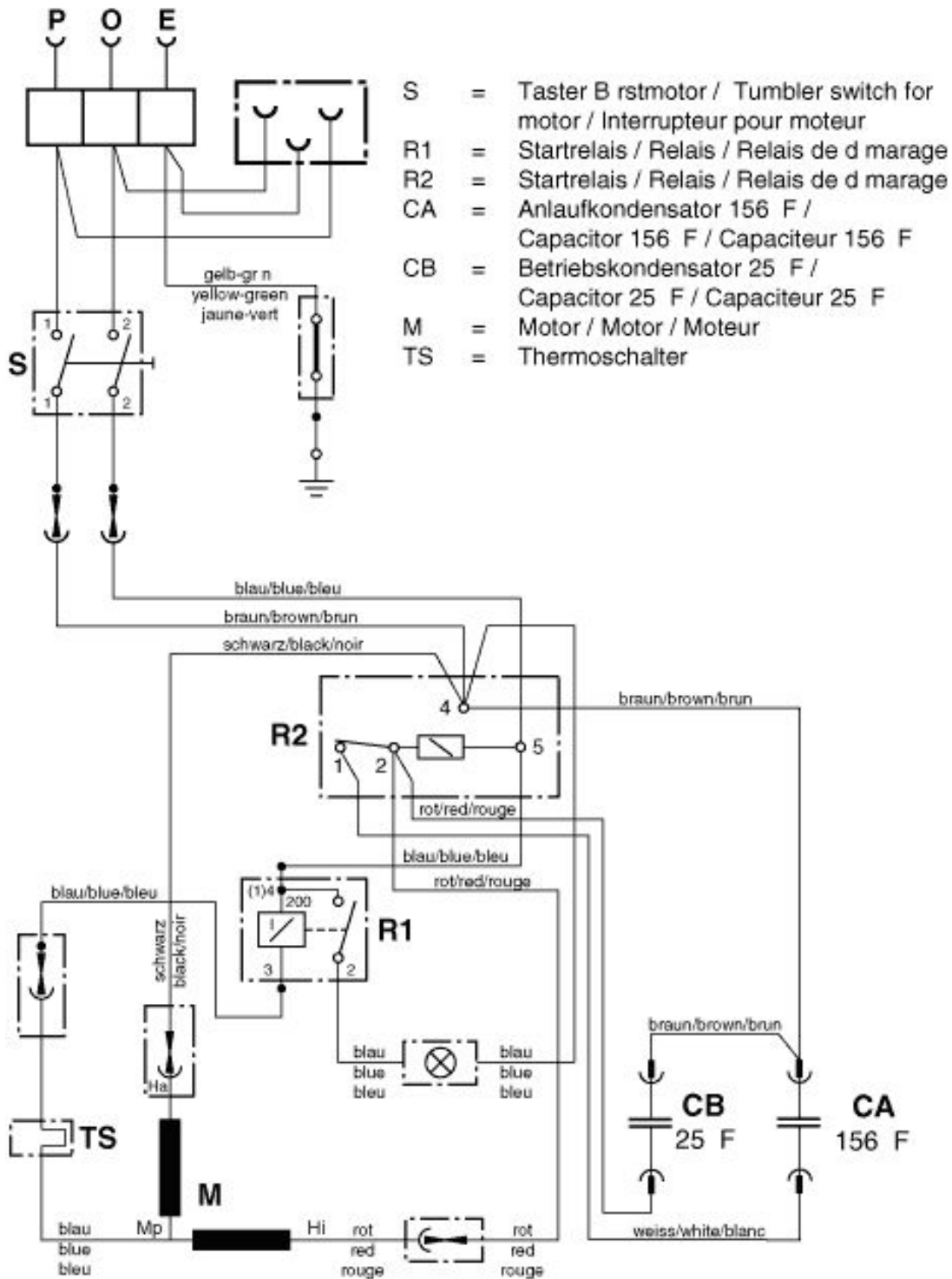

# R 53 -1100 / Ultra High-Speed Wiring diagram as from machine no. 8240

As at: 10/21/11 Time:12:18

<b>Pos.</b>	<b>Description</b>	<b>Reference</b>
CA	Capacitor 156 $\mu$ F	782.307
CB	Capacitor 25 $\mu$ F	P...385J
M	Motor	785.200
R1	Relais ER4 10.2/8.40A.702	420.331 A
R2	Relais as from machine no. 8240	P...350
S	Tumbler switch for motor	6650454
TS	thermoswitch	